

Service Schematics

NOKIA 5610 XpressMusic

RM-242



Introduction

Important:

This document is intended for use by authorized service centers only.

“Service Schematics” was created with focus on customer care.
The purpose of this document is to provide further technical repair information for NOKIA mobile phones on Level 3/4 service activities.
It contains additional information such as e.g. “Component finder”.

Saving process time and improving the repair quality is the aim of this document.
It is to be used additionally to the service manual and other training or service information such as Service Bulletins.

While every endeavour has been made to ensure the accuracy of this document, some errors may exist. If the reader finds any errors, NOKIA should be notified in writing.

Please send E-Mail to: TrainingAndVendor.Development@nokia.com

Table of contents

Frontpage	1
Sytem connector	2
AVILMA & BETTY	3
RAP3GS, microSD card & microphne	4
FM & BT module	5
Camera interface & HW accelerator	6
B2B connector & User interface	7
Camera & bottom flex	8
Top flex & top board	9
RF part	10
Component finder	11

Copyright © NOKIA

This material , including documentation and any related computer programs is protected by copyright, controlled by NOKIA. All rights are reserved. Copying, including reproducing, modifying, storing, adapting or translating any or all of this material requires the prior written consent of NOKIA. This material also contains confidential information, which may not be disclosed to others whitout the prior written consent of NOKIA.

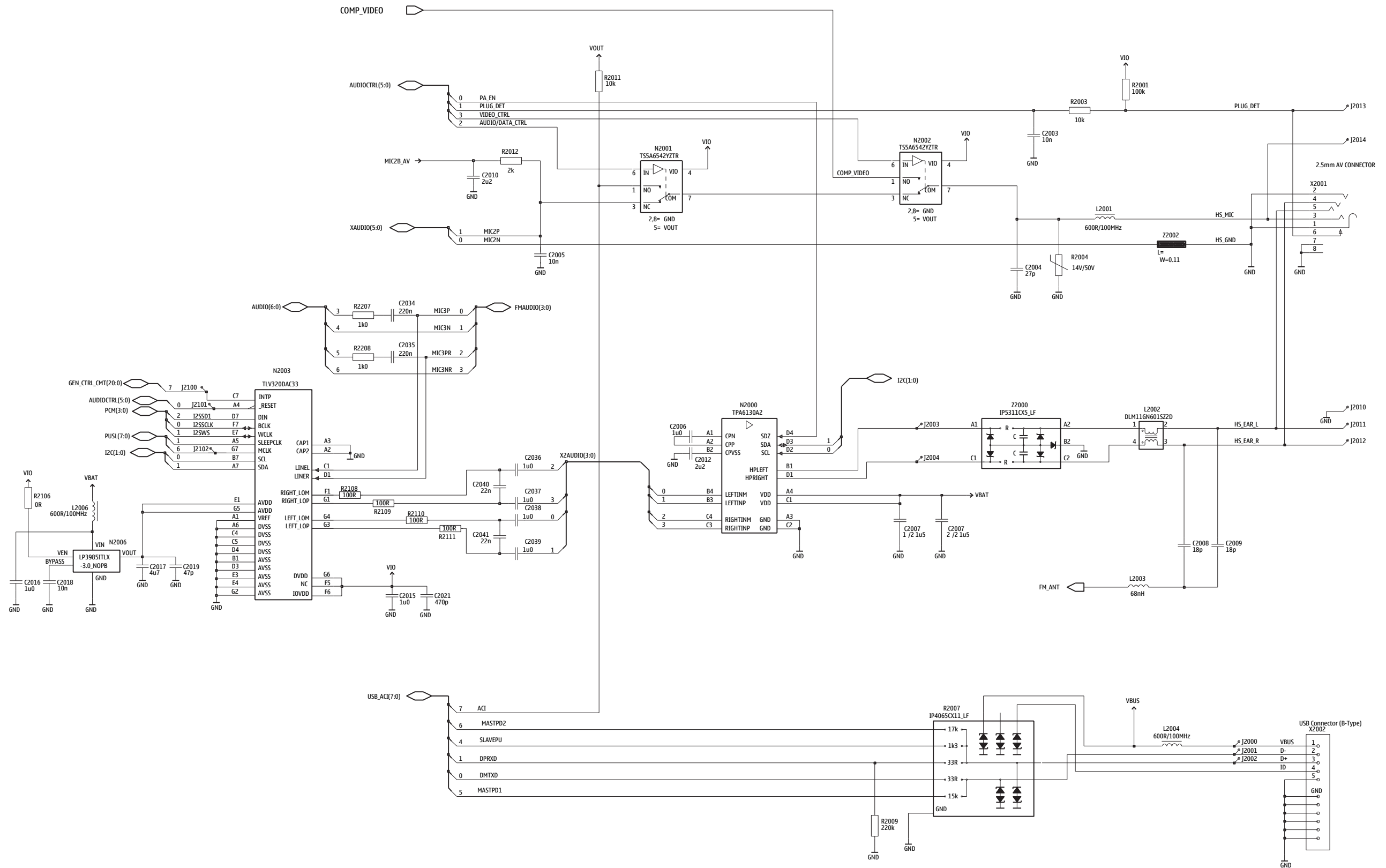

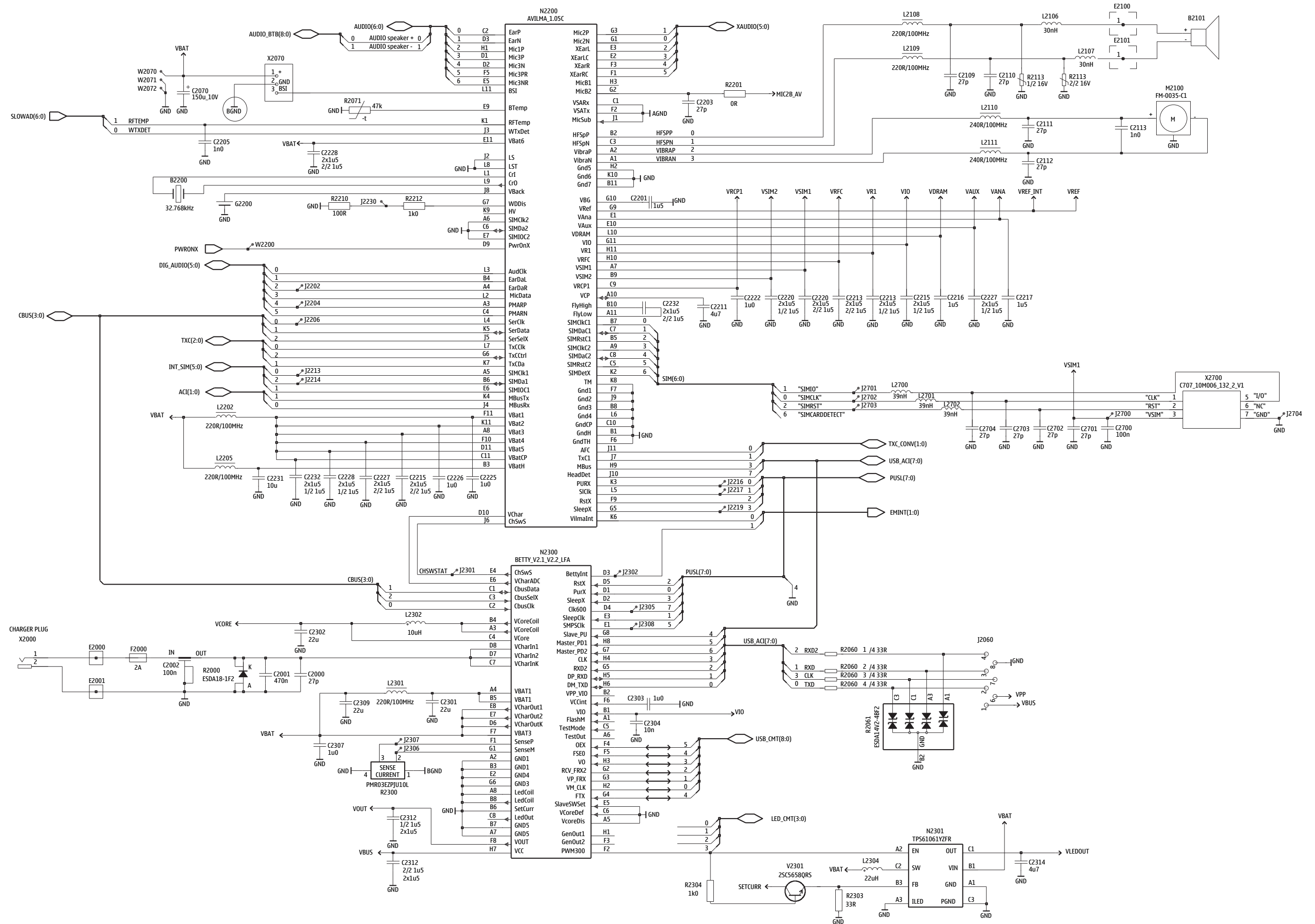

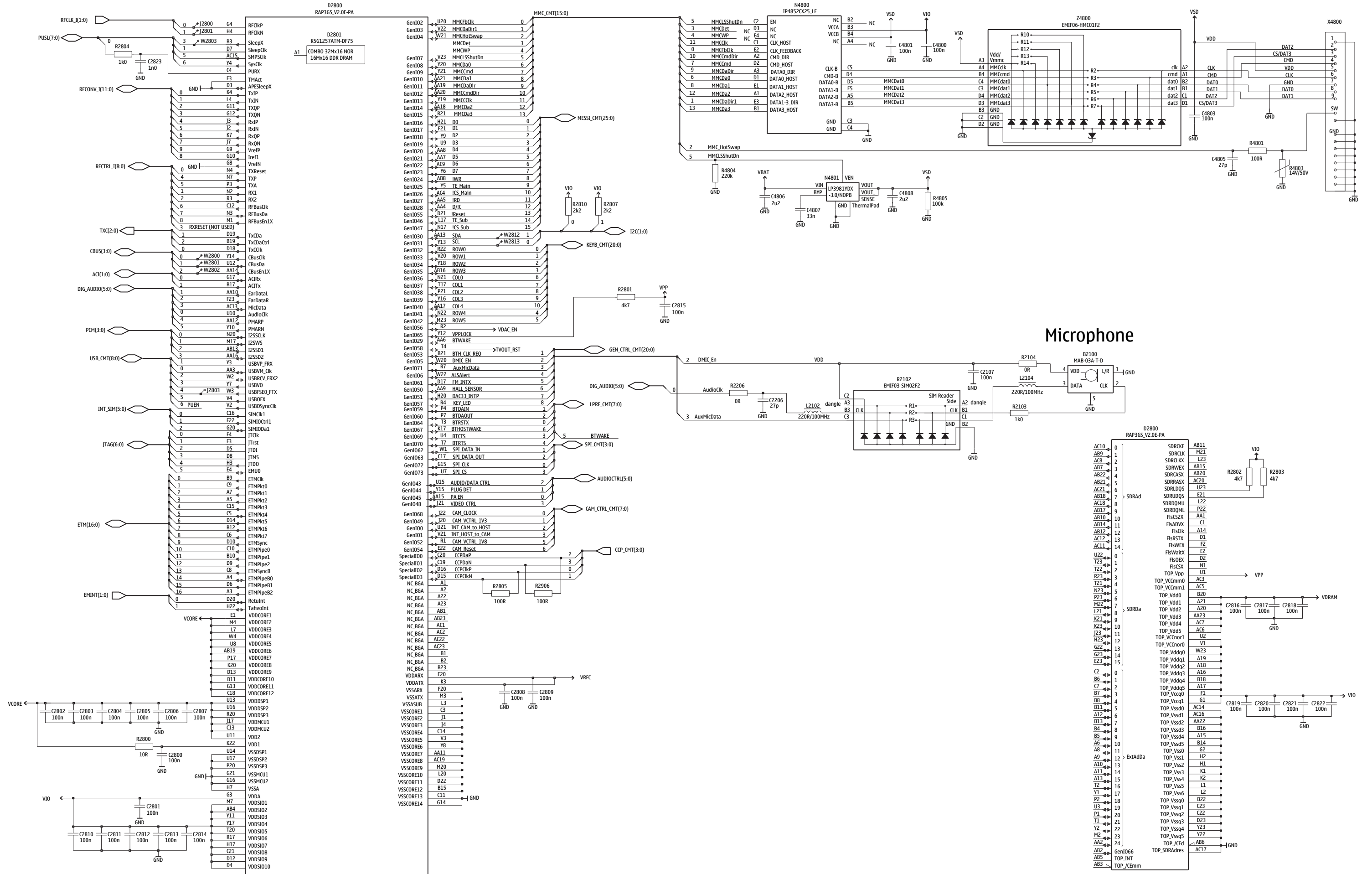

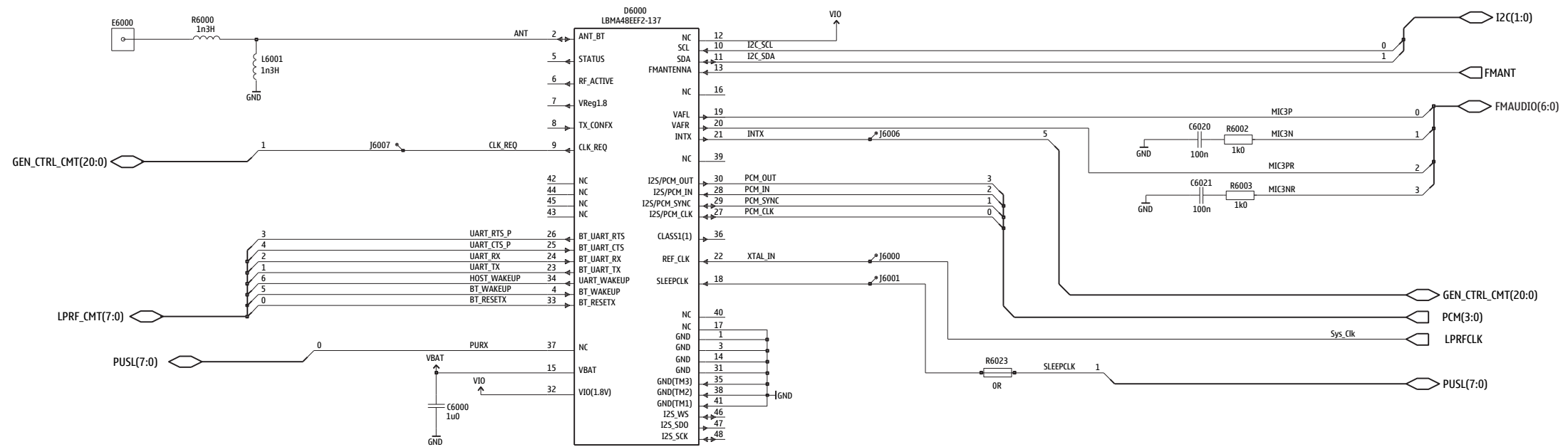

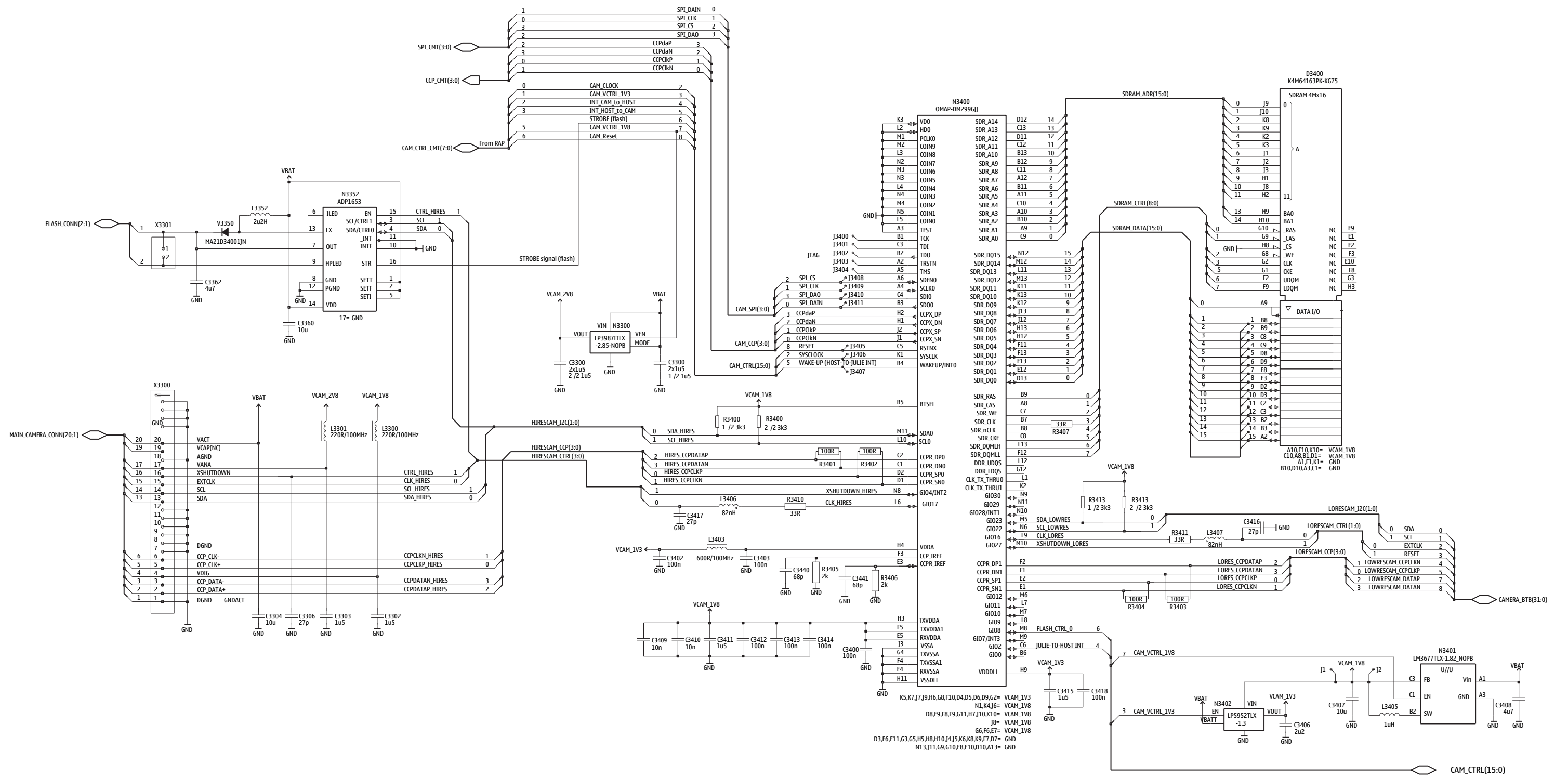

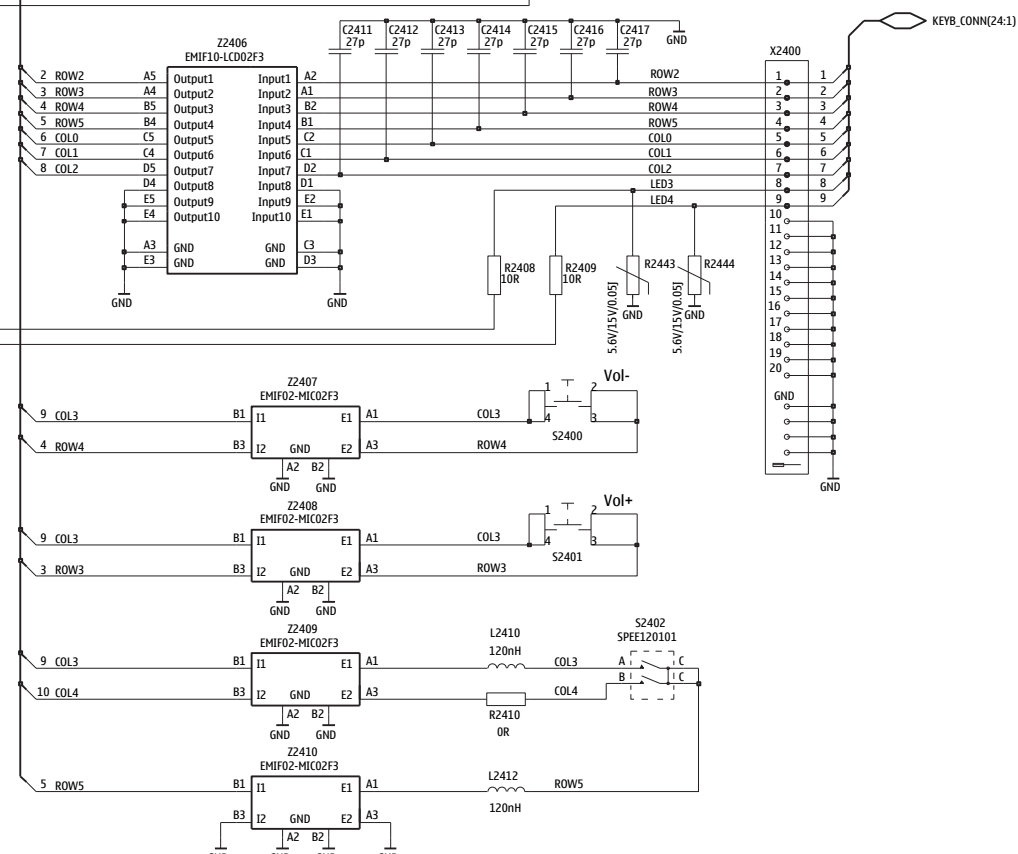
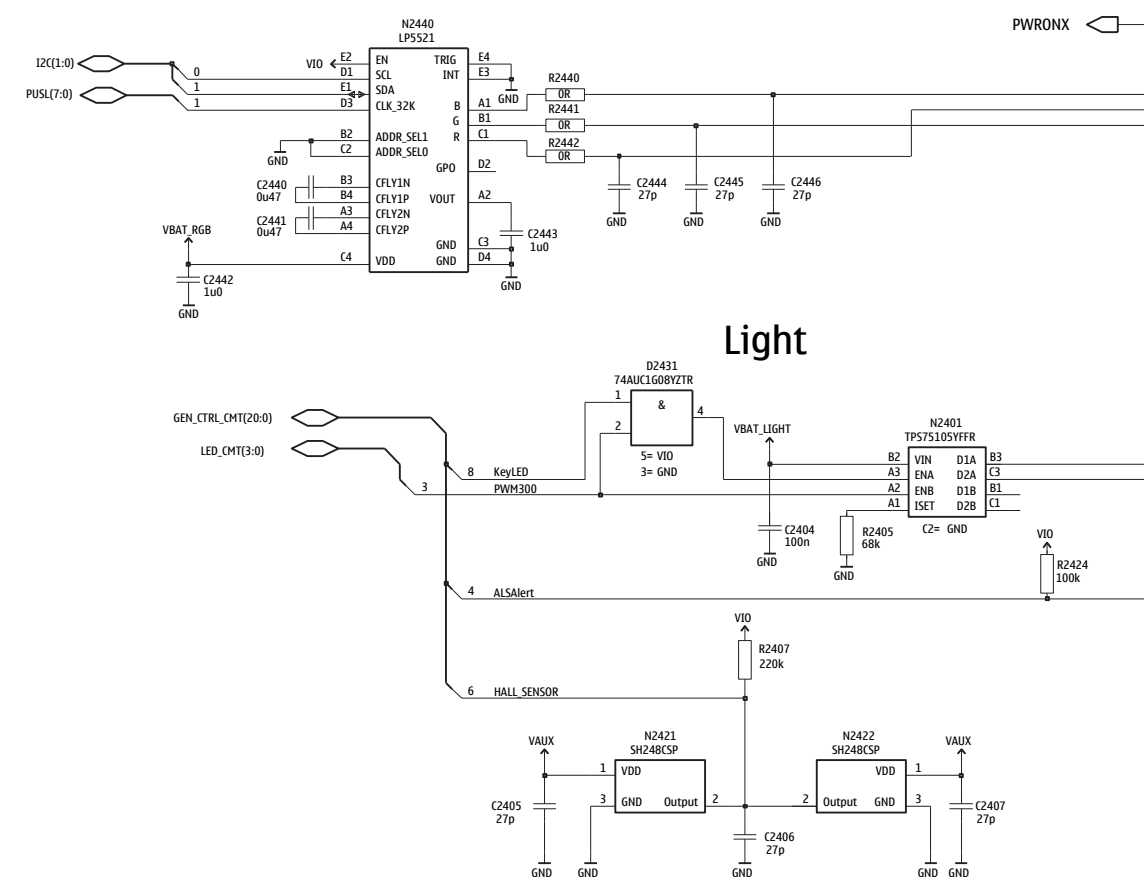
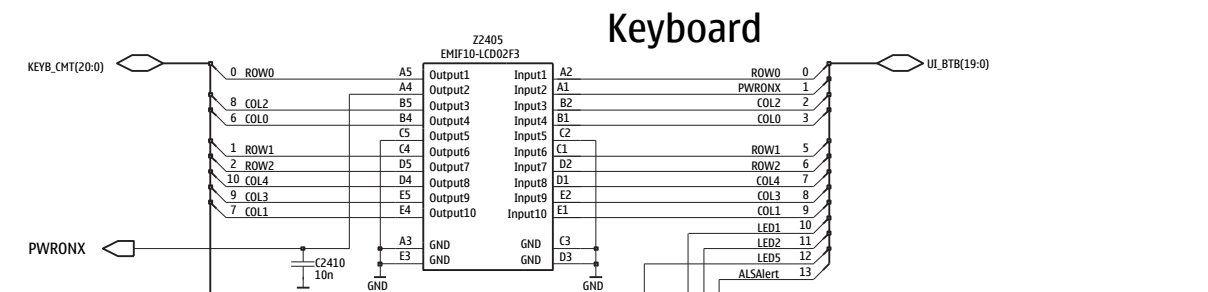
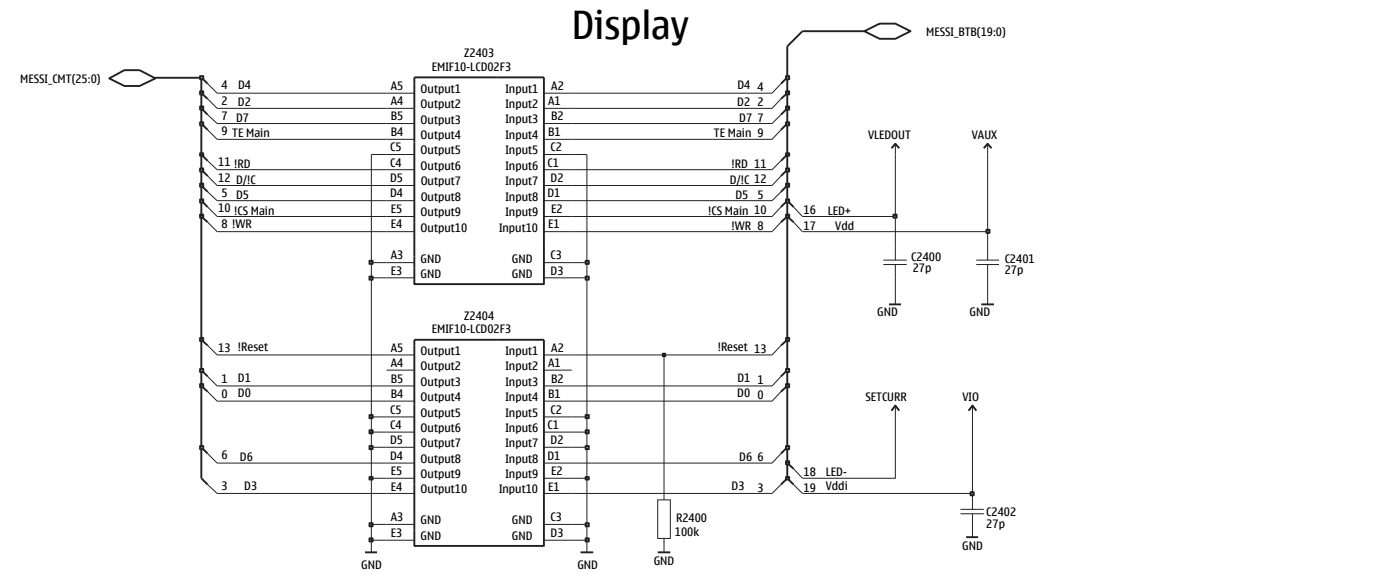
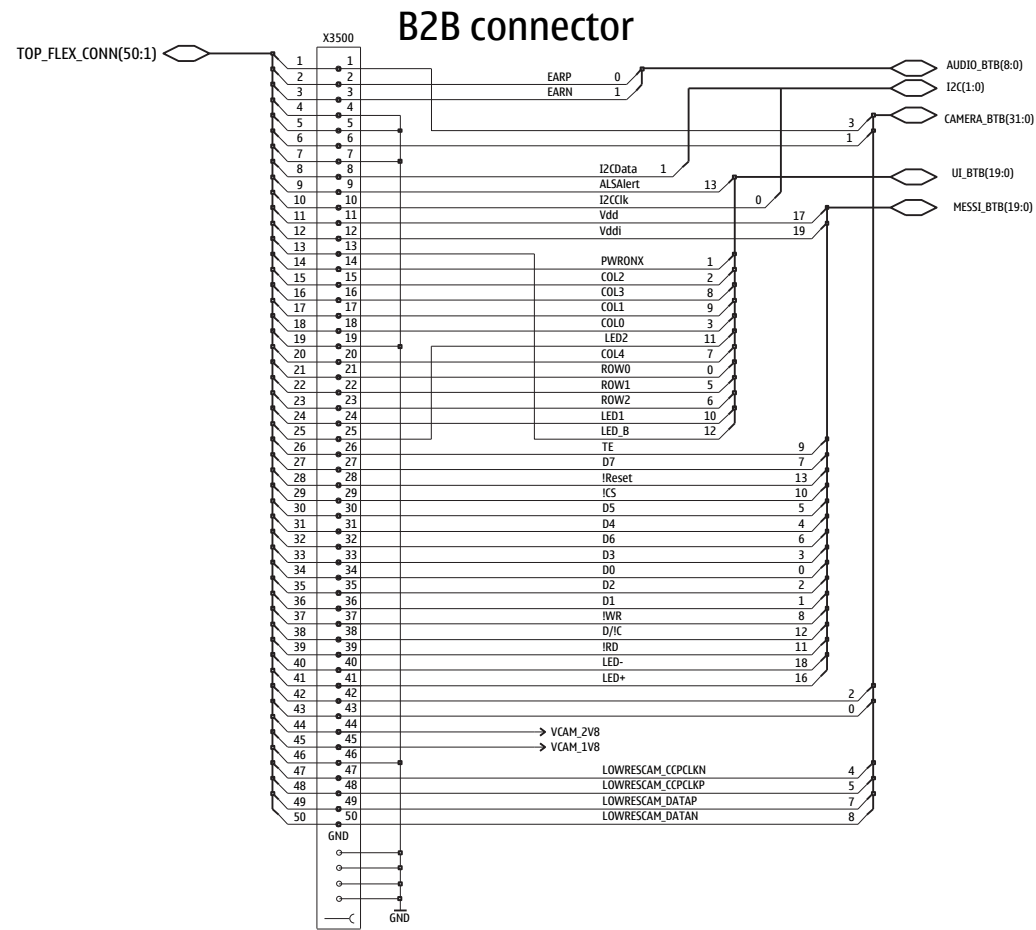

Camera Flex 2AMG_04

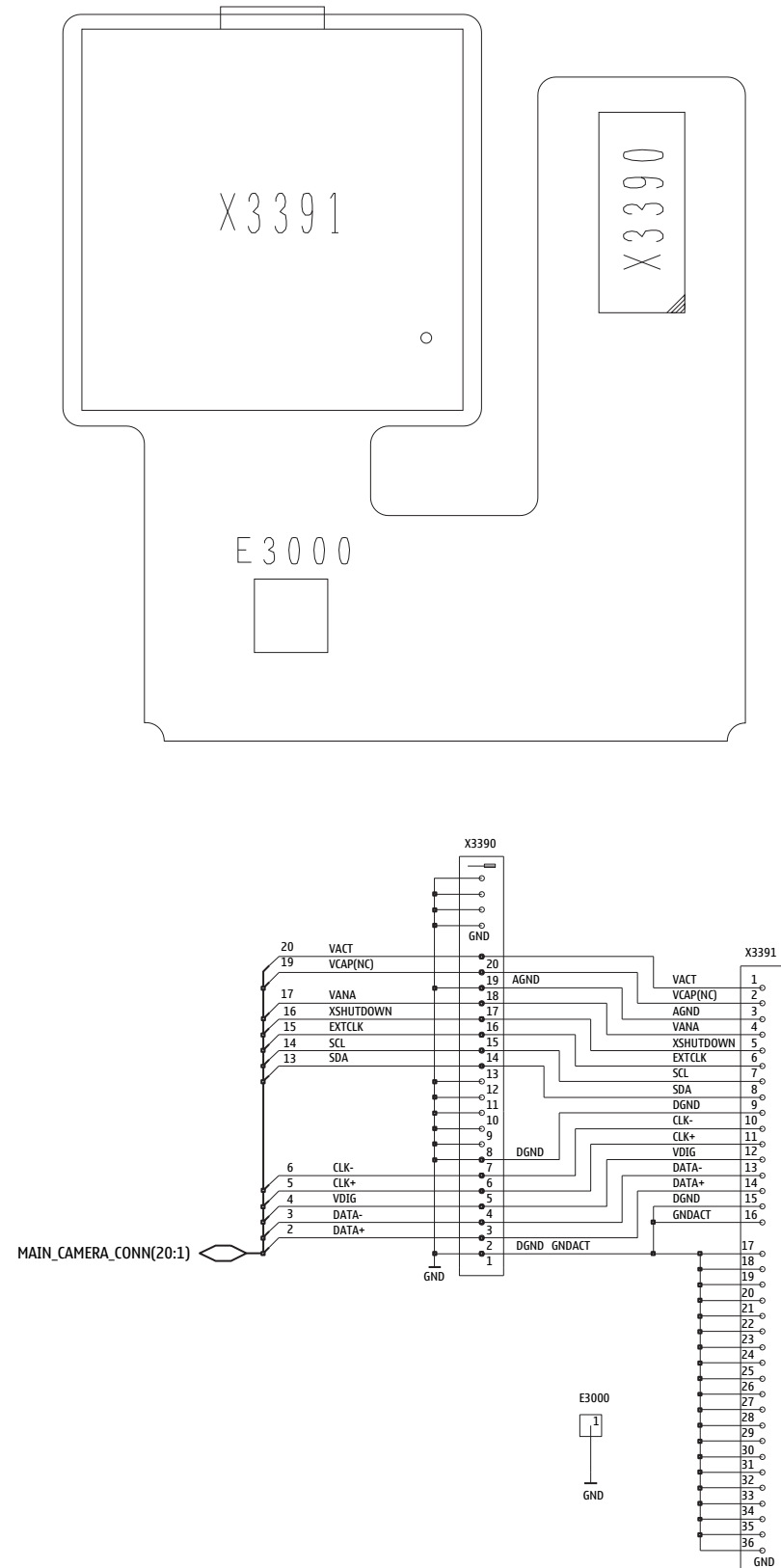

Bottom Flex 2AMC_03

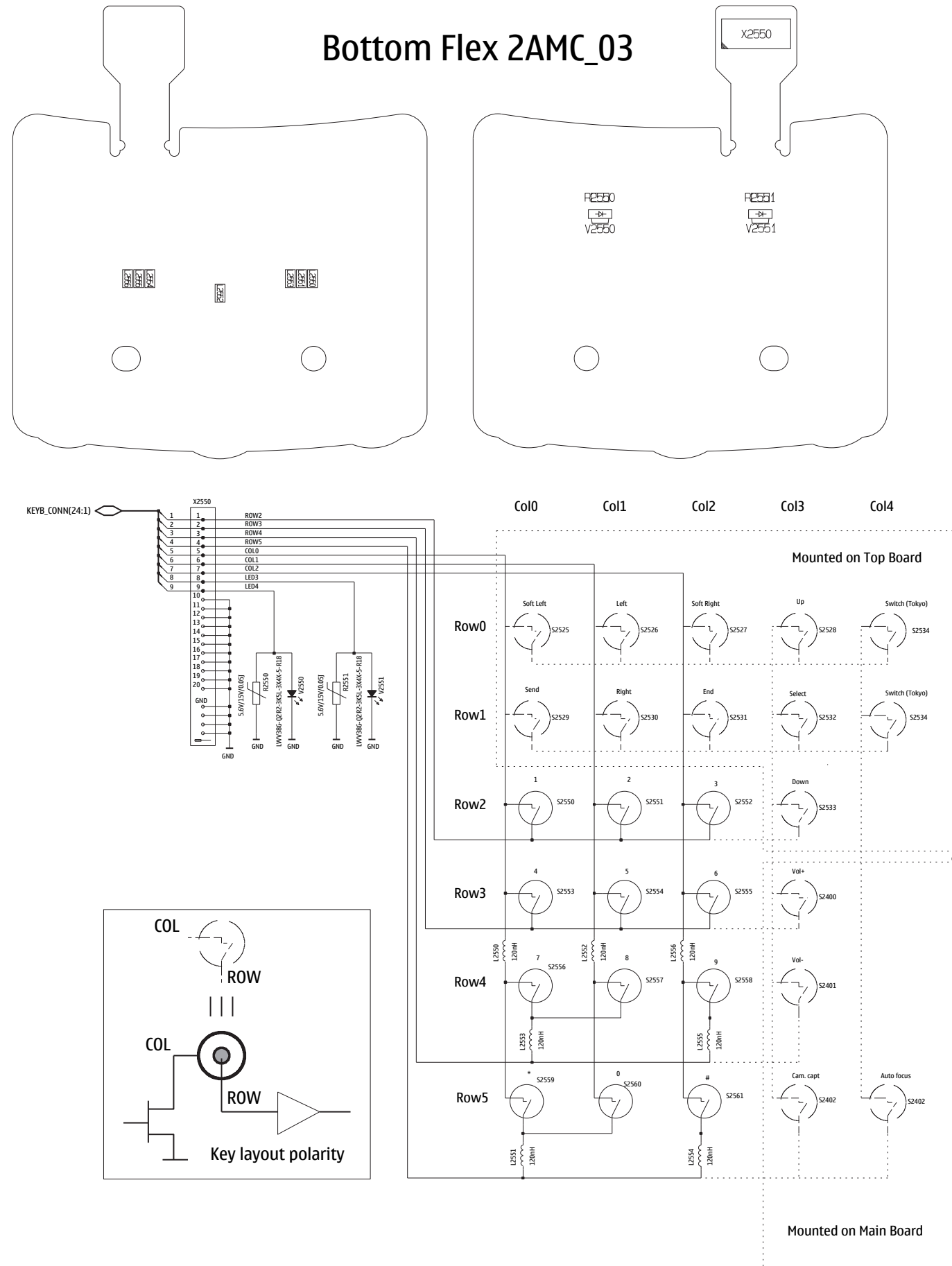

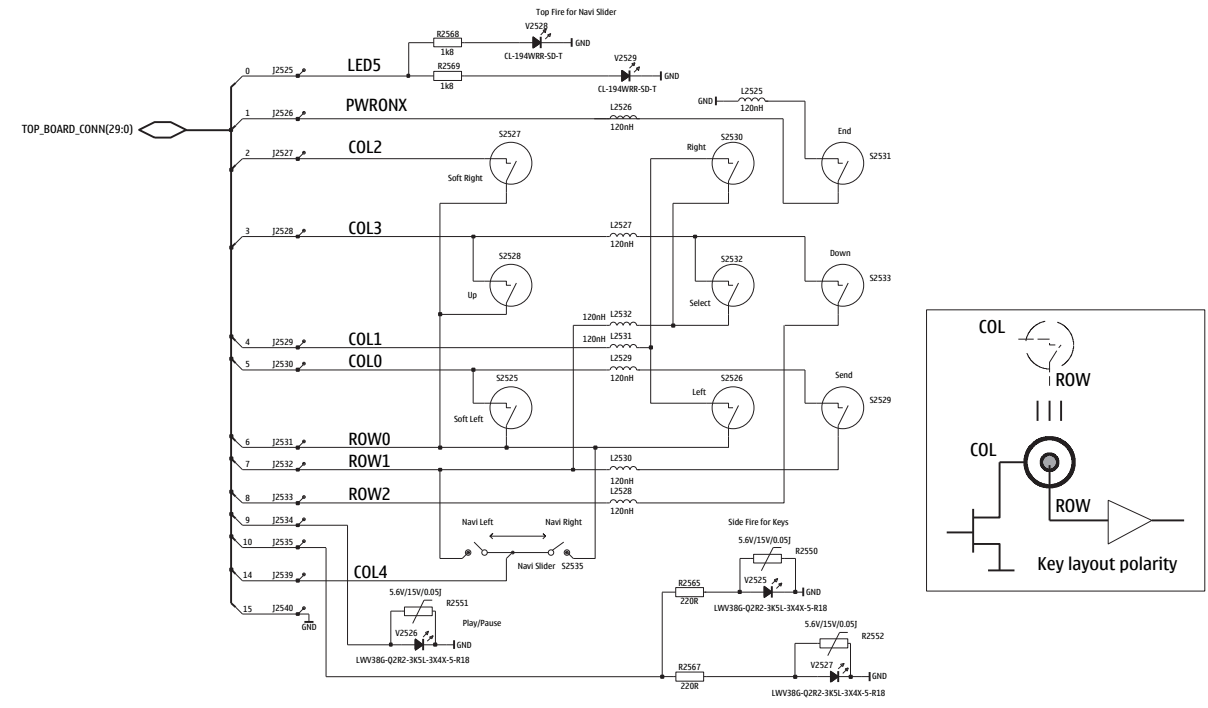
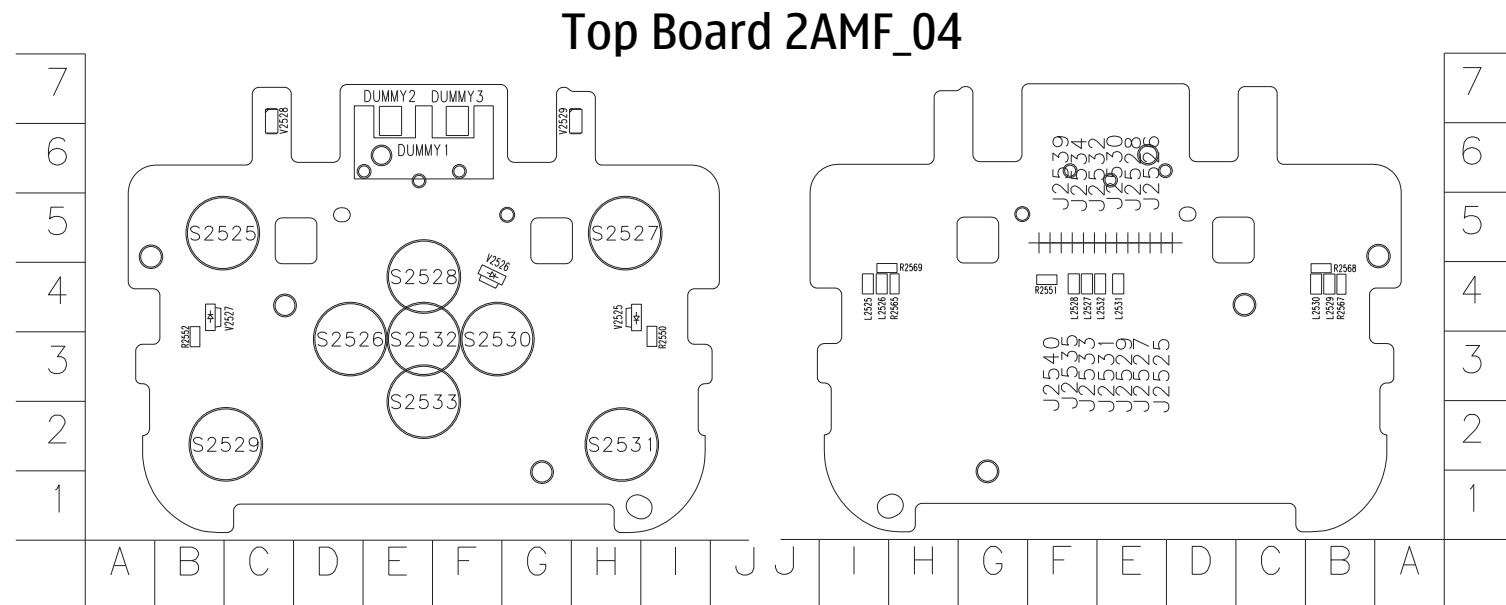
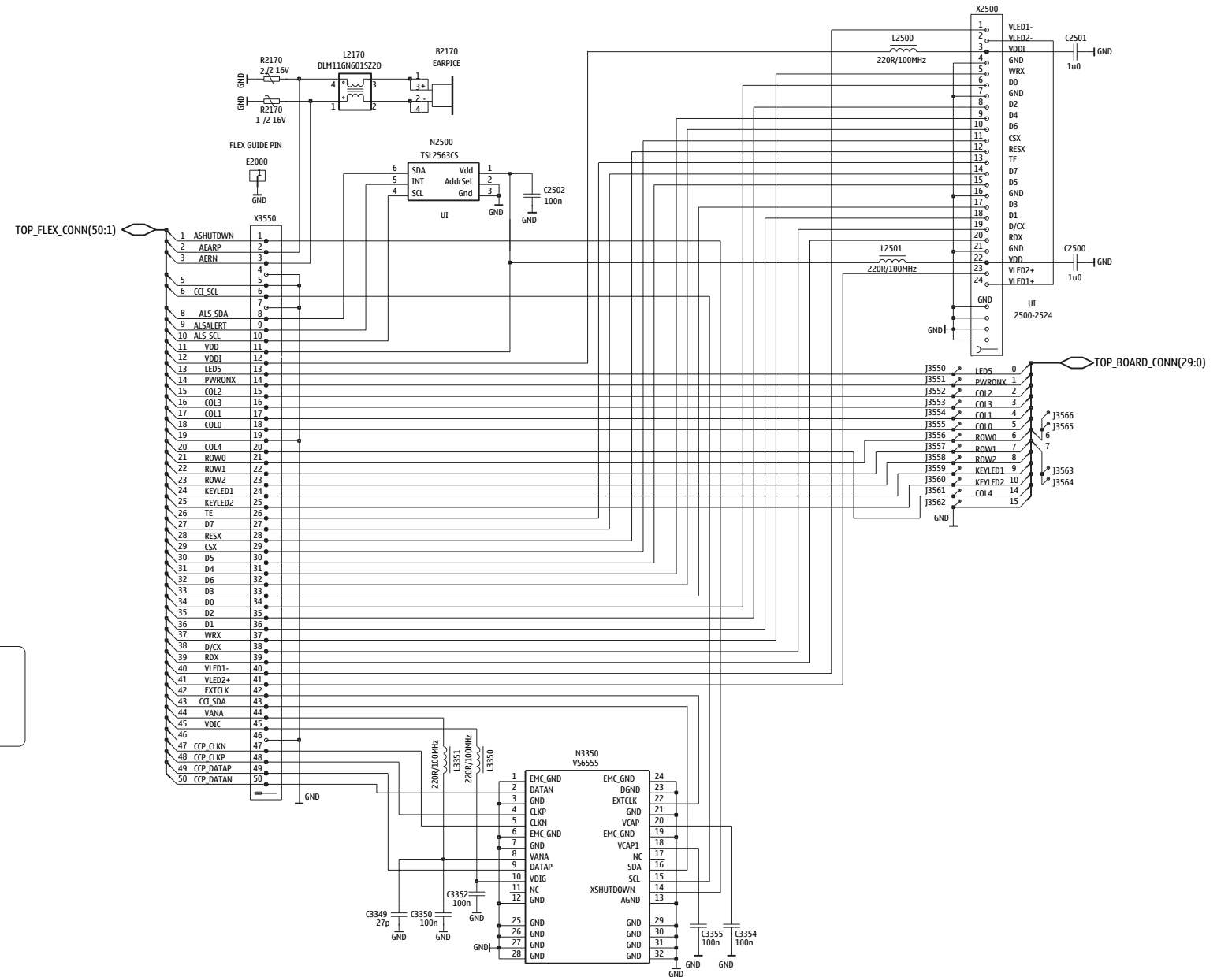
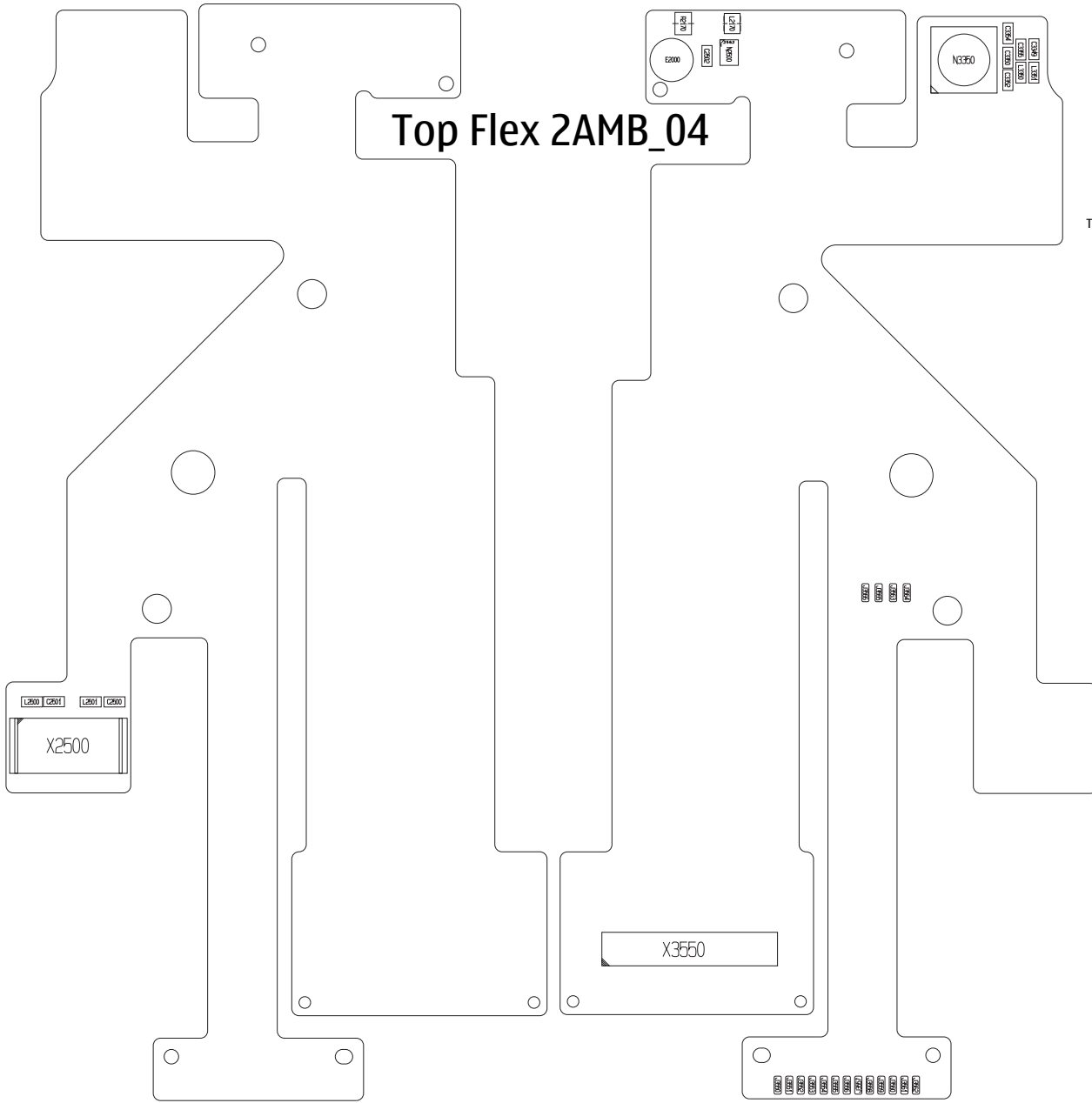

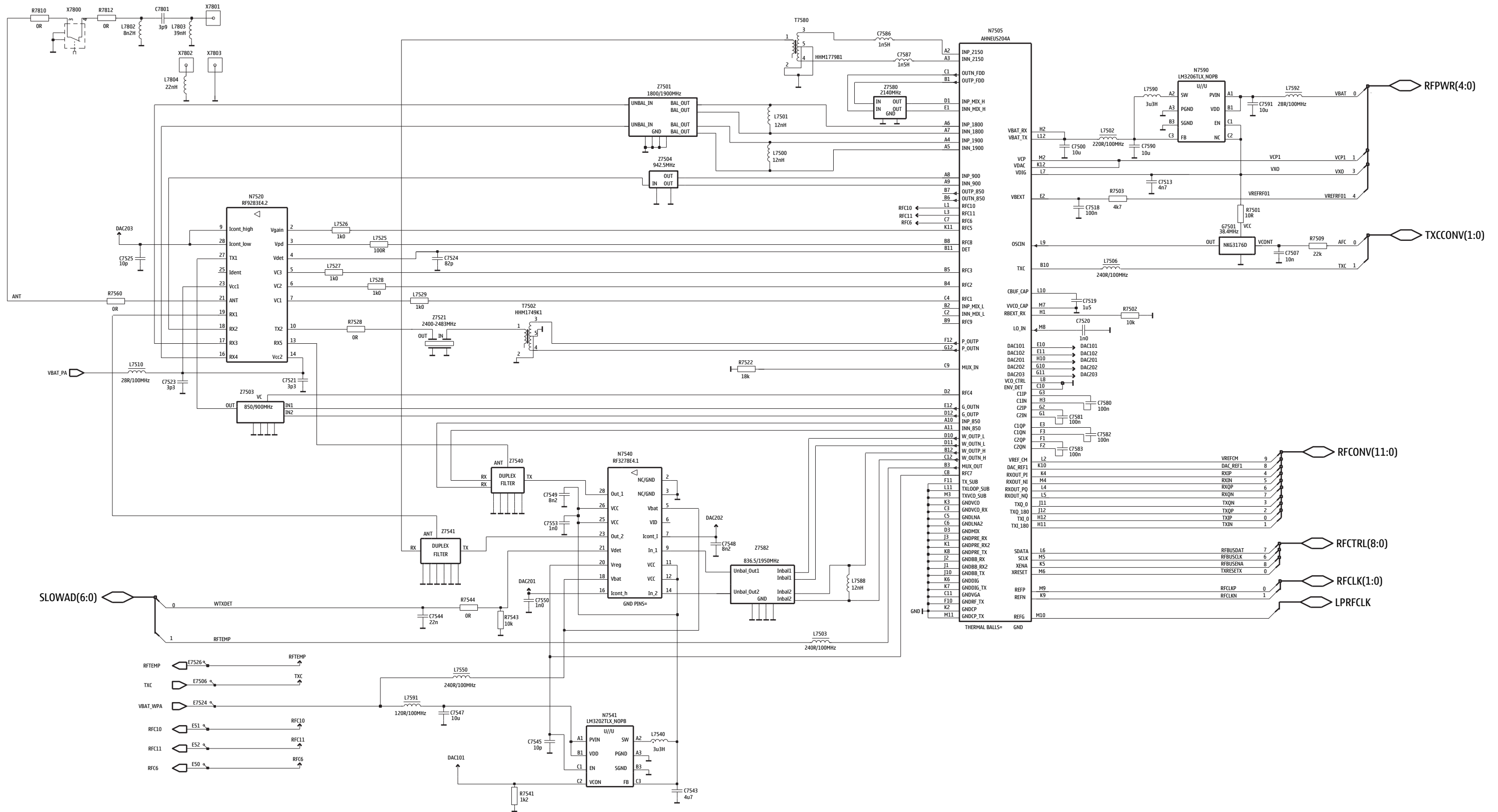

B		C2443	O9	C7545	F2	E7913	G9	J3400	L5	N2401	C3	R4804	N9
B2100	C9	C2444	N8	C7547	G2	E7914	E7	J3401	L5	N2421	L5	R4805	O8
B2200	J5	C2445	N9	C7548	F2	E7915	F9	J3402	L4	N2422	M5	R6000	C9
C		C2446	N9	C7549	F3	E7916	G9	J3403	M5	N2440	N9	R6002	Q6
C2000	P9	C2700	N4	C7550	F2	E7917	F9	J3404	M4	N3300	M5	R6003	Q6
C2001	P9	C2701	N4	C7553	E3	E7918	F9	J3405	M4	N3352	P5	R6023	J4
C2002	P8	C2702	N4	C7580	G8	E7919	F9	J3406	K4	N3400	L4	R7501	F8
C2003	O1	C2703	O4	C7581	G8	E7920	G9	J3407	M4	N3401	K5	R7502	G8
C2004	Q2	C2704	O7	C7582	G8	E7921	F9	J3408	M5	N3402	L5	R7503	G7
C2005	N1	C2800	I6	C7583	G8	E7922	F9	J3409	M4	N4800	O7	R7509	E8
C2006	Q3	C2801	H8	C7586	G6	E7923	F9	J3410	M4	N4801	N8	R7522	F7
C2007	R2	C2802	H6	C7587	F6	E7924	G3	J3411	M4	N7505	F7	R7528	E5
C2008	P2	C2803	H7	C7590	E6	E7925	G8	J6000	P8	N7520	F5	R7541	G2
C2009	P2	C2804	H8	C7591	E6	F		J6001	P7	N7540	E2	R7543	F2
C2010	O1	C2805	H6	C7801	C6	F2000	Q8	J6006	P7	N7541	G2	R7544	F2
C2012	Q2	C2806	I8	D		G		J6007	P6	N7590	E6	R7560	G3
C2015	P2	C2807	J7	D2431	D3	G2200	J4	J6020	P7	R		R7810	D5
C2016	P3	C2808	I8	D2800	I7	G7501	E8	J6021	P6	R2000	P9	R7812	C6
C2017	Q4	C2809	J6	D2801	I7	J		L		R2001	O1	S	
C2018	Q3	C2810	J6	D3400	L2	J1	K5	L2001	Q2	R2003	O1	S2400	M1
C2019	Q4	C2811	H8	D6000	Q7	J2	K4	L2002	P2	R2004	Q1	S2401	P1
C2021	P2	C2812	J8	E		J2000	Q6	L2003	P2	R2007	Q5	S2402	B1
C2034	R4	C2813	H6	E1	P7	J2001	Q6	L2004	Q6	R2009	P5	T	
C2035	P6	C2814	H7	E1000	G9	J2002	Q6	L2006	P4	R2011	N1	T7502	E5
C2036	R3	C2815	H8	E1001	G1	J2003	P1	L2102	D6	R2012	N1	T7580	G6
C2037	R3	C2816	H6	E1002	P9	J2004	P1	L2104	D6	R2060	L9	V	
C2038	R3	C2817	H8	E1003	P1	J2010	Q7	L2106	D3	R2061	M9	V2301	I2
C2039	R3	C2818	J6	E2000	R8	J2011	Q6	L2107	D2	R2071	L9	V3350	P5
C2040	Q3	C2819	H8	E2001	R8	J2012	Q6	L2108	H1	R2102	D6	W	
C2041	Q3	C2820	I8	E2100	D4	J2013	Q7	L2109	G1	R2103	D7	W2070	H8
C2070	D8	C2821	J7	E2101	D2	J2014	P1	L2110	I9	R2104	D7	W2071	I8
C2107	D6	C2822	H6	E2400	R5	J2060	K7	L2111	J9	R2106	Q5	W2072	G8
C2109	H1	C2823	J8	E2401	Q5	J2100	P3	L2202	H4	R2108	Q3	W2200	H5
C2110	H1	C3100	J8	E2402	C3	J2101	P3	L2205	H4	R2109	Q3	W2800	H8
C2111	I9	C3000	M6	E2403	O8	J2102	P3	L2301	H3	R2110	Q3	W2801	H9
C2112	J9	C3002	N4	E50	F7	J2202	I6	L2302	H2	R2111	Q3	W2802	G9
C2113	D8	C3003	N5	E51	G9	J2204	H7	L2304	H3	R2113	D2	W2803	I9
C2201	I5	C3004	N4	E52	F9	J2206	I2	L2410	B2	R2201	I3	W2812	H9
C2203	I3	C3006	O4	E53	E4	J2213	J7	L2412	B1	R2206	H4	W2813	H8
C2205	I4	C3360	O4	E6000	C9	J2214	I6	L2700	O7	R2207	R4	X	
C2206	H4	C3362	M4	E6001	P6	J2216	I2	L2701	O4	R2208	Q6	X2001	Q3
C2207	D6	C3400	M3	E7010	E4	J2217	J2	L2702	N4	R2210	I4	X2002	R5
C2211	H5	C3402	K5	E7506	E7	J2219	J3	L3300	M4	R2212	I4	X2060	C6
C2213	I5	C3403	K4	E7524	G2	J2230	H3	L3301	N6	R2300	D7	X2070	E7
C2215	I5	C3406	L5	E7526	G8	J2301	J2	L3352	P4	R2303	H3	X2400	C4
C2216	J5	C3407	K5	E7528	E6	J2302	J3	L3403 <th>K5</th> <th>R2304</th> <th>H3</th> <th>X2700</th> <th>N6</th>	K5	R2304	H3	X2700	N6
C2217	H3	C3408	K5	E7530	G8	J2305	I3	L3405 <th>K5</th> <th>R2400</th> <th>O6</th> <th>X3300</th> <th>N5</th>	K5	R2400	O6	X3300	N5
C2220	H4	C3409	K2	E7534	E8	J2306	J2	L3406	O4	R2405	C2	X3301	Q4
C2222	H5	C3410	K2	E7536	G7	J2307	J2	L3407	M5	R2407	L5	X3500	O7
C2225	J5	C3411	M5	E7540	E7	J2308	J2	L6001	C9	R2408	C3	X4800	O6
C2226	H5	C3412	K3	E7542	G9	J2430	Q6	L7500	F7	R2409	D3	X7800	C5
C2227	I5	C3413	K4	E7544	G9	J2431	Q6	L7501	F6	R2410	B1	X7801	B7
C2228	H5	C3414	M4	E7546	F9	J2432	Q6	L7502	E7	R2424	N7	X7802	B8
C2231	H4	C3415	K3	E7548	F8	J2433	R4	L7503	G7	R2434	N6	X7803	B7
C2232	H5	C3416	M5	E7550	E8	J2435	Q6	L7506	E8	R2440	N9	Z	
C2301	I2	C3417	O4	E7552	E8	J2436	P6	L7510	E4	R2441	N9	Z2000	P2
C2302	I2	C3418	L5	E7554	E8	J2700	M6	L7525	G6	R2442	N8	Z2002	R3
C2303	I2	C3440	K4	E7556	E8	J2701	M5	L7526	G6	R2443	C3	Z2403	N8
C2304	I2	C3441	L5	E7558	F9	J2702	M6	L7527	G5	R2444	C3	Z2404	N8
C2307	J3	C4800	N7	E7560	F9	J2703	M6	L7528	G5	R2800	I6	Z2405	N6
C2309	H3	C4801	O7	E7562	F9	J2704	M5	L7529	G4	R2801	H7	Z2406	D3
C2312	J3	C4803	O7	E7564	F9	J2800	I8	L7540	G3	R2802	H7	Z2407	N1
C2314	I3	C4805	O4	E7566	F9	J2801	I8	L7550	F2	R2803	J6	Z2408	O1
C2400	O7	C4806	O8	E7568	G9	J2803	I2	L7588	E7	R2804	J8	Z2409	C2
C2401	P7	C4807	N8	E7570	F9	J3100	I8	L7590	E6	R2805	J7	Z2410	C2
C2402	P7	C4808	O9	E7572	F9	J3101	H8	L7591	F2	R2807	I8	Z3300	N5
C2404	C2	C6000	P6	E7574	F9	J3102	H8	L7592	E6	R2810	H8	Z3301	N5
C2405	L5	C6020	Q6	E7814	G3	J3103	H7	L7802	C6	R2906	J6	Z3500	O8
C2406	L5	C6021	Q6	E7900	M6	J3104	I7	L7803	C7	R3400	K3	Z3501	O8
C2407	M5	C7500	F8	E7901	G9	J3105	I7	L7804	C8	R3401	L5	Z4800	O7
C2410	N6	C7507	E7	E7902	E8	J3110	I8	M		R3402	L5	Z7501	F6
C2411	C4	C7513	F8	E7903	F9	J3111	J8	M2100	D7	R3403	L5	Z7503	F6
C2412	D4	C7518	G7	E7904	F9	J3112	I7	N		R3404	L5	Z7504	F7
C2413	D4	C7519	F8	E7905	F9	J3113	I7	N2000	Q2	R3405	K4	Z7521	E5
C2414	C4	C7520	F8	E7906	F9	J3114	I7	N2001	N1	R3406	L5	Z7540	E3
C2415	C5	C7521	G4	E7907	E8	J3115	I7	N2002	O1	R3407	M2	Z7541	F3
C2416	C4	C7523	E4	E7908	E8	J3116	I7	N2003	P3	R3410	N4	Z7580	G6
C2417	C5	C7524	F6	E7909	E8	J3117	H7	N2006	P4	R3411	M5	Z7582	E7
C2440	O9	C7525	G5	E7910	E8	J3118	H7	N2200	I5	R3413	K3		
C2441	O9	C7543	F3	E7911	E7	J3119	H7	N2300	I2	R4801	O4		
C2442	N9	C7544	F2	E7912	G7	J3120	I7	N2301	H3	R4803	O4		

